

## Video Article

# A Practical Guide on Coupling a Scanning Mobility Sizer and Inductively Coupled Plasma Mass Spectrometer (SMPS-ICPMS)

Mohamed Tarik<sup>1</sup>, Debora Foppiano<sup>1,2</sup>, Adrian Hess<sup>1,3</sup>, Christian Ludwig<sup>1,2</sup><sup>1</sup>Bioenergy and Catalysis Laboratory (LBK), Energy and Environment Research Division (ENE), Paul Scherrer Institute<sup>2</sup>Environmental Engineering Institute (IIE), School of Architecture, Civil and Environmental Engineering (ENAC), École; Polytechnique Fédérale de Lausanne (EPFL)<sup>3</sup>Institute for Atmospheric and Climate Science ETH ZurichCorrespondence to: Mohamed Tarik at [mohamed.tarik@psi.ch](mailto:mohamed.tarik@psi.ch)URL: <https://www.jove.com/video/55487>DOI: [doi:10.3791/55487](https://doi.org/10.3791/55487)

Keywords: Chemistry, Issue 125, Aerosol, suspension, rotating disk diluter, SMPS, ICPMS, elemental analysis, size distribution, nanoparticles

Date Published: 7/11/2017

Citation: Tarik, M., Foppiano, D., Hess, A., Ludwig, C. A Practical Guide on Coupling a Scanning Mobility Sizer and Inductively Coupled Plasma Mass Spectrometer (SMPS-ICPMS). *J. Vis. Exp.* (125), e55487, doi:10.3791/55487 (2017).

## Abstract

A large variety of analytical methods are available to characterize particles in aerosols and suspensions. The choice of the appropriate technique depends on the properties to be determined. In many fields information about particle size and chemical composition are of great importance. While in aerosol techniques particle size distributions of gas-borne particles are determined online, their elemental composition is commonly analyzed offline after an appropriate sampling and preparation procedure. To obtain both types of information online and simultaneously, a hyphenated setup was recently developed, including a Scanning Mobility Particle Sizer (SMPS) and an Inductively Coupled Plasma Mass Spectrometer (ICPMS). This allows first to classify the particles with respect to their mobility diameter, and then to determine their number concentration and elemental composition in parallel. A Rotating Disk Diluter (RDD) is used as the introduction system, giving more flexibility regarding the use of different aerosol sources. In this work, a practical guide is provided describing the different steps for establishing this instrumentation, and how to use this analysis tool. The versatility of this hyphenated technique is demonstrated in example measurements on three different aerosols generated out of a) a salt solution, b) a suspension, and c) emitted by a thermal process.

## Video Link

The video component of this article can be found at <https://www.jove.com/video/55487/>

## Introduction

In numerous fields, the characterization of particles in aerosols and suspensions – including the determination of chemical composition and size distribution – is an important issue. A variety of analytical techniques to determine particle properties is used in different environmental, industrial and research applications, such as measuring/monitoring air-borne or combustion-emitted particles, characterizing synthesized engineered nano-objects, and studying their health and environmental effects.

Size information of gas-borne particles and particles in suspensions is conventionally analyzed by different particle sizers, such as an Aerodynamic Particle Sizer (APS), Dynamic Light Scattering devices (DLS), or a Scanning Mobility Particle Sizer (SMPS)<sup>1,2,3,4,5</sup>. The latter – well-established aerosol measurement tool – consists of two parts, a Differential Mobility Analyzer (DMA) and a Condensation Particle Counter (CPC). Both instruments are mounted in series. The first one allows the classification of the aerosol particles according to their mobility diameters in an air stream by varying the voltage between two electrodes<sup>6</sup>. In the CPC, entering nanoparticles act as condensation nuclei, "large" droplets are formed, and then they are optically counted<sup>6</sup>. The SMPS output data represent size-resolved number information about the measured particles and are given as Particle Size Distributions (PSD).

On the other hand, the chemical characterization of gas-borne particles and particles in suspensions is usually performed offline<sup>7</sup>. An appropriate collection and sample preparation procedure is required prior to the analysis. Such offline investigations usually include the application of a spectroscopic technique, such as Inductively Coupled Plasma Mass Spectrometry (ICPMS). This is an established method in element and trace-element analysis of liquid samples with very high sensitivity and low detection limits<sup>8</sup>. In ICPMS, an argon plasma serves to dry and decompose introduced samples into atomic ions. These are then classified according their mass to charge ratio ( $m/z$ ) and finally counted in analog or pulsed mode. Besides liquid samples, this technique is also used for gas and particle analysis. For example, gas can be directly introduced into the ICPMS and analyzed<sup>9,10,11</sup>. In speciation analysis, a Gas Chromatograph (GC) coupled to ICPMS is used to separate and detect volatile compounds<sup>12</sup>. ICPMS was further developed to so-called single particle ICPMS (sp-ICPMS) in order to characterize monodisperse particles in suspensions<sup>13,14</sup>. Other surface and/or bulk analytical techniques are used either to achieve a complete characterization, and/or to gain more information about the particle characteristics. Imaging techniques, such as Scanning Electron Microscopy (SEM) and Transmission Electron Microscopy (TEM), are widely used for this purpose<sup>15,16,17</sup>.

To simultaneously gain time-resolved chemical and size information, two different analytical techniques, such as SMPS and a plasma spectrometric technique, can be combined in one setup<sup>18</sup>. This online measurement concept can avoid problems related to sample collection,

preparation and offline analysis procedure. A short overview of previous attempts to develop such a combined setup was reported by Hess et al.<sup>19</sup>.

In this work, a detailed description of a combined SMPS-ICPMS measuring arrangement and procedure is given. A Rotating Disk Diluter (RDD) is used as the introduction interface. The development of this hyphenated technique and three application studies can be found in the literature<sup>19,20,21</sup>. Figures of merit given by Hess et al.<sup>20</sup> show that the performance of the developed SMPS-ICPMS instrumentation is comparable to that of the separate state-of-the-art systems. This study is complementary to the previous publications<sup>19,20,21</sup> and gives a laboratory practice describing how this setup can be used. Example applications on aerosols from two different sources are shortly described, to show the versatility of the coupled system.

Before describing the measurement protocol, it is worth summarizing the individual components and the coupling strategy of the hyphenated setup. A more detailed description can be found elsewhere<sup>19</sup>. The main components of the coupled setup are: an aerosol source, RDD, DMA, CPC, and ICPMS.

To generate dried aerosol particles from a suspension or liquid solution, an aerosol generator equipped with a nozzle and a silica gel drier is used. A detailed description can be found elsewhere<sup>19</sup>. To investigate thermal processes, a Thermogravimetric Analyzer TGA (or a tubular furnace) is utilized.

The RDD is used for the aerosol sample introduction<sup>22</sup>. It consists of a heatable steel block equipped with two channels, and a rotating disk featuring several cavities. The channels are flushed with dilution gas and raw aerosol from the aerosol source. Depending on the gas flows and the disk rotation speed, a certain amount of raw aerosol is added to the dilution gas, resulting in a defined dilution ratio. Argon is used as dilution gas, because of the low air tolerance of the ICPMS. However, the DMA voltage limit should be set lower than that of air-operated DMA, in order to avoid electric arcing. Since the flow of diluted sample aerosol at the RDD outlet can be precisely controlled independently of the raw aerosol flow, the RDD sampling concept can be used for different aerosol sources. A heated tube (up to 400 °C) is installed between RDD and SMPS, to evaporate volatile particles, and/or to further dilute the aerosol. This step is needed to achieve good reproducibility when processing samples containing organic matter. However, this may also trigger chemical reactions. Pyrolysis, for instance, starts at much lower temperatures and may decompose not only particles but also induce some chemical reactions. The SMPS used in this work consists of a DMA tube (similar to long DMA; see Materials table), and a commercial CPC. Before entering the DMA, the diluted aerosol must pass a radioactive source, called an aerosol neutralizer, in order to establish a known charge equilibrium (assuming a Boltzmann charge distribution)<sup>6</sup>. The particles are then classified according to their mobility diameter by varying the voltage at given DMA sheath and aerosol gas flows. The flow split at the DMA outlet is done such that 30% of the aerosol are directed to the CPC, the other 70% to the ICPMS. The number concentration of the classified particles is determined by the CPC. The other aerosol portion is analyzed by a commercial ICPMS instrument, allowing the elemental analysis of the aerosol-loaded particles. Since no liquids are investigated, the conventional sample introduction system is removed and the DMA outlet is directly connected to the ICPMS. A second RDD and another air-operated commercial SMPS are used as reference instruments to validate the PSD measured by the SMPS-ICPMS coupled setup. The RDD-SMPS reference system is connected to the raw aerosol outlet of the RDD of the coupled system.

## Protocol

### 1. RDD-SMPS-ICPMS Setup

#### 1. Coupling strategy of the RDD-SMPS-ICPMS setup

NOTE: In order to couple the different instruments, *i.e.* RDD, SMPS and ICPMS, and to control the different gas flows, some modifications in the instrumental arrangements are needed. The main steps of the coupling concept are summarized here:

1. Use conductive tubing with inner/outer diameters 6.0/12.0 mm (carbon impregnated silicone tubing) to connect the different instrumental parts.
2. Install the Rotating Disk Diluter between the aerosol source and the Differential Mobility Analyzer, or DMA, where the particle size classification takes place. Split the classified aerosol at the DMA outlet in two fractions. One will be aspirated by the Condensation Particle Counter, or CPC. The other is guided towards the Inductively Coupled Plasma Mass Spectrometer, or ICPMS (**Figure 1**).
3. Use a mass flow controller (MFC) and a filter, such as a High-Efficiency Particulate Air filter (HEPA), to provide the RDD with particle-free dilution argon.
4. Add another filter at the RDD outlet for the excess raw gas ( $Q_{\text{RDD out}}$ ). Check the performance of all the filters in use from time to time while using the CPC.
5. Use another MFC and filter to adjust the sheath gas flow ( $Q_{\text{sheath}}$ ) introduced to the DMA.
6. To adjust the DMA excess gas flow ( $Q_{\text{DMA exc}}$ ), mount a filter, MFC, and vacuum pump in series at the DMA outlet.
7. Connect an additional MFC and filter to add particle free air ( $Q_{\text{CPC air}}$ ) to the CPC, as makeup flow to reduce the amount of classified aerosol ( $Q_{\text{CPC class}}$ ), consumed by the CPC.

NOTE: This is because the CPC actively aspirates a flow defined by a critical orifice and an external pump, which is about 1 L/min. The classified flow rate at the ICP inlet ( $Q_{\text{ICP in}}$ ) is the difference between the flow rate at the DMA outlet ( $Q_{\text{class}}$ ) and  $Q_{\text{CPC class}}$ .

### 2. Measurement Protocol for RDD-SMPS-ICPMS

NOTE: Before tuning the SMPS-ICPMS parameters, the flows used for the aerosol generator must be set. Here, the procedure of using liquid and solid samples is described.

#### 1. Example of aerosol sources

1. Using aerosol generator for liquids and suspensions

1. For an example of using an aerosol generator for a suspension, prepare a zinc oxide (ZnO) suspension from a commercial ZnO nanopowder (e.g. with a nominal diameter of 50 nm) and poly-acrylic acid as stabilizer for the nanoparticles. Dilute the prepared suspension to obtain a ZnO concentration of approx. 30 µg/mL. This concentration is chosen because it will lead to a good ICPMS signal later, with all the gas flows applied.
2. For the second measurement prepare an aqueous sodium chloride (NaCl) solution with a concentration of 200 µg/mL.
  1. First, fill the suspension or solution into the bottle and mount it on the aerosol generator.
3. Use the aerosol generator to generate an aerosol from the salt solution or the particle suspension, and to remove the water from the particles in the silica gel drier.
  1. Set the compressed air valve of the aerosol generator slightly above 1 bar. Adjust the This results in an aerosol flow behind the diffusion drier to about of approximately 1 L/min. Finally, connect the outlet of the drier to the RDD inlet.

2. Using thermogravimeter or a tubular furnace

NOTE: As an example for applying the RDD-SMPS-ICPMS in measuring emissions from thermal processes, a copper chloride (CuCl<sub>2</sub>) sample is analyzed. Two aerosol sources are used, namely a TGA and a tubular furnace. In both cases, the reactive gas (e.g. O<sub>2</sub>), which is used for the thermal process, is mixed with argon to the appropriate ratio in order to prevent nucleation and condensation. In this work only the measurement procedure and representative data from a TGA experiment are presented.

1. First, tare the empty TGA crucible. Weigh 50 mg of CuCl<sub>2</sub> powder and place it in a crucible.
2. Adjust one MFC for the reactive gas (O<sub>2</sub>) to about 20 mL/min.
3. Set the flow of the protective gas (argon) to about 80 mL/min. At the TGA outlet, add an argon flow of about 900 mL/min to get a total flow of about 1 L/min (i.e. the sum of the flows of O<sub>2</sub>, protective argon and added argon). If the RDD pump is used, adjust the MFC to reach the required flow.
4. Set the desired temperature program (25 °C for 18 min and 450 °C for 15 min).

2. **Setting the flows**

NOTE: To achieve a stable operation of the RDD-SMPS-ICPMS setup, all the gas and aerosol flows should be adjusted carefully as described below. In this section, an example of a set of parameter values for adjusting the RDD, SMPS and ICPMS are given. Another set of parameters is possible; the procedure will however remain the same. The flow abbreviations used are listed in **Figure 1**. In the following steps use a flowmeter, such as a flow calibrator, to measure the different gas and aerosol flows before starting the measurement.

1. First set the argon sheath flow at the DMA inlet to 3 L/min.
2. Set the temperature of the RDD heating block to 80 °C, and that of the evaporation tube to 350 °C.
3. Adjust the mass flow controller of the dilution argon in order to obtain 0.6 L/min as flow of the diluted sample at the outlet of the rotating disk diluter (Q<sub>sample</sub>). The ratio 0.6/3 of the sheath gas to the sample gas is chosen to cover a particle size ranging from about 14 to about 340 nm.
4. Then, carefully adjust the excess gas mass flow controller (Q<sub>DMA exc</sub>) to achieve a classified aerosol flow of 0.6 L/min (Q<sub>class</sub>), the same flow rate as that of the diluted polydispersed aerosol at the DMA inlet (Q<sub>poly</sub>).
5. Next, Place the flow calibrator between DMA and CPC, and adjust the CPC makeup air flow, to reduce the flow rate of classified aerosol aspirated by the CPC to 0.18 L/min. This corresponds to 30% of Q<sub>class</sub>.
6. Check the remaining flow of classified aerosol to ensure that 0.42 Liter per min are directed to the ICPMS, i.e. 70% of the classified aerosol (Q<sub>class</sub>). Slight change of this flow can be corrected by fine-tuning the MFC of the DMA excess gas again.

3. **Setting the SMPS software**

1. Next, calculate the dynamic viscosity and the mean free path of argon at ambient temperature and pressure<sup>23</sup>. Enter both values in the SMPS software.
2. In the SMPS software, set the up and down scan durations of the DMA scanning cycle to 150 s and 30 s (i.e. 1 DMA cycle = 1 scan = 180 s).
3. In the SMPS software, set the DMA maximum voltage to 4.5 kV to cover the PSD interval ranging from about 14 to about 340 nm. NOTE: A voltage maximum of 10 kV is normally used in air-operated SMPS. Due to the lower dielectric strength of argon relative to that of air, the limit should be set lower in this application, since otherwise electric arcing would occur, leading to instrument damage and signal errors.

4. **Setting the ICPMS**

1. Remove the conventional introduction system of liquid samples to introduce dry aerosol directly into ICPMS. Add a conductive tube between the respective port of DMA outlet and the ICPMS. Use this tube for xenon (Xe), with a concentration of about 100 ppmv in argon matrix, to optimize the ICPMS plasma prior to each measurement and to control the plasma stability during the measurement.
2. Maintain the Xe flow constant for all measurements (e.g. at 4 mL/min) and tune the other parameters in the ICPMS software, including ICP dilution gas and sampling depth, to achieve a fixed Xe intensity.

NOTE: The main ICPMS tuning parameters are listed in **Table 1**. The parameters to be tuned prior to each measurement are indicated in the last column.

3. Set the SMPS and ICPMS acquisition time to cover the desired total duration of the aerosol measurement (e.g., for 10 SPMS scan, set the ICPMS acquisition time to at least 30 min).
4. After setting the gas flows and the SMPS and the ICPMS parameters run the two instruments manually at the same time. In the case of the TGA, acquire SMPS and ICPMS blank signals at 25 °C for 18 min (6 scans). In the case of the suspension or liquid sample, acquire blank signals during 2 scans of 6 min with the disk rotation speed set to zero. Then set the dilution factor of the RDD to the desired value by adjusting the disk rotation speed manually. With the current configuration, 100% rotating speed corresponds to a dilution factor of 14.9.

5. **Data analysis**

NOTE: ICPMS measures the ion intensity per unit time (unit: count per second, or cps) for each  $m/z$ . This intensity is proportional to the analyte mass. SMPS data represent the number-weighted PSD of classified aerosol ( $PSD_n$ ) entering the DMA (unit:  $1/cm^3$ ), based on the number concentrations determined by the CPC behind the DMA. To compare both ICP and SMPS signals, the volume-weighted PSD ( $PSD_v$ ) must be calculated. The following calculations and corrections should be made:

1. Export the raw signal intensities versus time for each  $m/z$  from the ICPMS data, and the  $PSD_n$  determined by the SMPS software – as a function of the particle diameter ( $d_p$ ). From the SMPS raw data, export the particle diameter and the corresponding scanning time. Use the latter in order to correlate the ICPMS measurement time with the particle diameter (see below).  
NOTE: The SMPS software must consider that the aerosol flow at the DMA outlet is split, and only 30% of the classified particles reach the CPC. This can be achieved by multiplying the counting efficiency values – stored in a separate table as type-specific CPC characteristics – by a factor of 0.3.
2. Since the desired information is not primarily the particle concentration between RDD and DMA, but that at the RDD inlet, multiply the measured concentrations by the RDD dilution factor, *i.e.* 14.9 in the current configuration.
3. To calculate volume-weighted data from the original number-weighted SMPS data, multiply the recorded concentrations of  $PSD_n$  by the volume  $V(d_p)$  of the measured particles<sup>5</sup> ( $V(d_p) = (\pi/6) \cdot d_p^3$ ).
4. Calculate the ICPMS net signal by subtracting the background signal from the raw ion signal for each isotope. Then, multiply the net signal by the inverse single charge probability  $1/p^{+1}(d_p)$  to get the corrected ICP intensity, which is approximately proportional to the concentration at the DMA inlet and hence at the RDD inlet (assuming no particle losses between RDD inlet and ICPMS or CPC inlets).
  1. Calculate the probability of particles to carry one elemental positive charge by using the Wiedensohler approximation<sup>24</sup>. For the SMPS data processed by the SMPS software, the correction for this charge probability is normally implemented in the software.
5. For a given SMPS scan, plot the SMPS particle concentration or the ICPMS intensity as a function of particle diameter in an x-y diagram. In the case of a steady-state aerosol, use the same type of diagram to present the concentration or intensity averaged over several scans.
6. For a series of scans, use 2D surface or 3D diagrams to plot the SMPS concentration or ICPMS intensity as functions of diameter and time. In the case of thermal processes, if a temperature program is used, substitute the time by the corresponding temperature values.  
NOTE: Moreover, the calculations needed for ICPMS and SMPS data to make such plots can be automated using calculation software like MATLAB or Igor Pro, which allows for obtaining robust final results in a short time.

## Representative Results

In the first example, the setup is used as tool to measure online particles generated from a ZnO suspension (**Figure 2**). As can be seen in **Figure 2A-2B**, the  $PSD_v$  appears shifted towards larger particles when compared to  $PSD_n$ . Moreover, at large particle diameters, the ICPMS intensity curve lies slightly below the curve detected by SMPS. In the second example, the particles were generated from an aqueous NaCl solution (200  $\mu\text{g/mL}$ ) using the same aerosol generator (**Figures 3A-3C**). The ICPMS and SMPS signals do not show a substantial change with time, and the time-resolved signal of sodium correlates well to the  $PSD_v$  during the entire measuring period. Unlike Zn in the previous example, Na has a relatively high ICPMS background signal, resulting in a noisier signal than that of the concentrations recorded by the SMPS. As in the ZnO suspension sample, the mode of the  $PSD_n$  lies at a lower particle diameter than that of the  $PSD_v$ . Since the generated particles are NaCl particles, the behavior of the Cl signal is like that of Na and correlates well with the volume-related SMPS data (data not shown).

In the last example, the results of the thermal treatment of a  $\text{CuCl}_2$  sample by using the TGA are presented. **Figure 4A** shows the  $PSD_n$  recorded for particles down to 20 nm at the beginning of the TGA heating (at about 21 min on time axis, *i.e.* at the beginning of the 7<sup>th</sup> SMPS scan). Afterwards the particle concentration in  $PSD_n$  reaches a steady state when the temperature is maintained constant and the particles cover a size range between 60 and 250 nm. A slight increase is observed in the particle size after the 11<sup>th</sup> SMPS scan (at about 30 min on time axis). Considering  $PSD_v$  (**Figure 4B**), the contribution of the different particle sizes is quite different to that of  $PSD_n$ , and with the  $PSD_v$  becoming high mainly between 150 and 330 nm. The ICPMS signal of Cu shown in **Figure 3C** correlates well with  $PSD_v$ . **Figure 4D-4E** shows the corrected and raw  $^{35}\text{Cl}$  intensity during the up and down scans, respectively. After the starting point of the heating period, beside the intensity corresponding to particles of chlorine species, constant Cl intensity covers the particle size range was measured (in the time interval 18 to 33 min, *i.e.* from the 7<sup>th</sup> to the 11<sup>th</sup> SMPS scan). This is due to the evaporation of Cl gaseous species. The chlorine particulates are recorded in the same size range as copper, namely in particles with diameters above 150 nm. Another experiment using the same sample ( $\text{CuCl}_2$ ) is performed without SMPS and by using only the TG-RDD-ICPMS setup. Here the ICPMS signal of the non-classified aerosol particles is measured (**Figure 4F**). Similar to the case of SMPS-ICPMS, an increase of both signals (Cl and Cu) in the last scans can be observed.

The results reported in this work demonstrate the versatile use of the coupled SMPS-ICPMS system with different aerosol sources. In the examples presented the correlation between the time-resolved ICPMS signal of Cu and  $PSD_v$  is obvious. For an aerosol loaded with different particles, the contribution of each element in the overall  $PSD_v$  is determined by the ICPMS signals. Moreover, the example of NaCl shows that keeping the experimental conditions constant results in a steady state time-resolved signal. The SMPS-ICPMS setup allows to monitor any change in elemental and/or size concentration of the generated aerosol. For instance, the higher signal of  $PSD_n$  in the  $\text{CuCl}_2$  experiment (**Figure 4C**) may be caused by the abrupt start of the heating process. Meanwhile, the increase in SMPS and ICPMS signals during the final scans can be explained by the change of the temperature gradient of the  $\text{CuCl}_2$  sample with time, which changes the total amount of the material reaching the evaporation temperature. Finally, considering the SMPS output data, the concentration in  $PSD_v$  is shifted towards larger particle size than in  $PSD_n$ . This is because the signal is multiplied with the 3<sup>rd</sup> power of the particle diameter to convert  $PSD_n$  to  $PSD_v$ , resulting in stronger weighting of large particles in the volume than in the number regime.

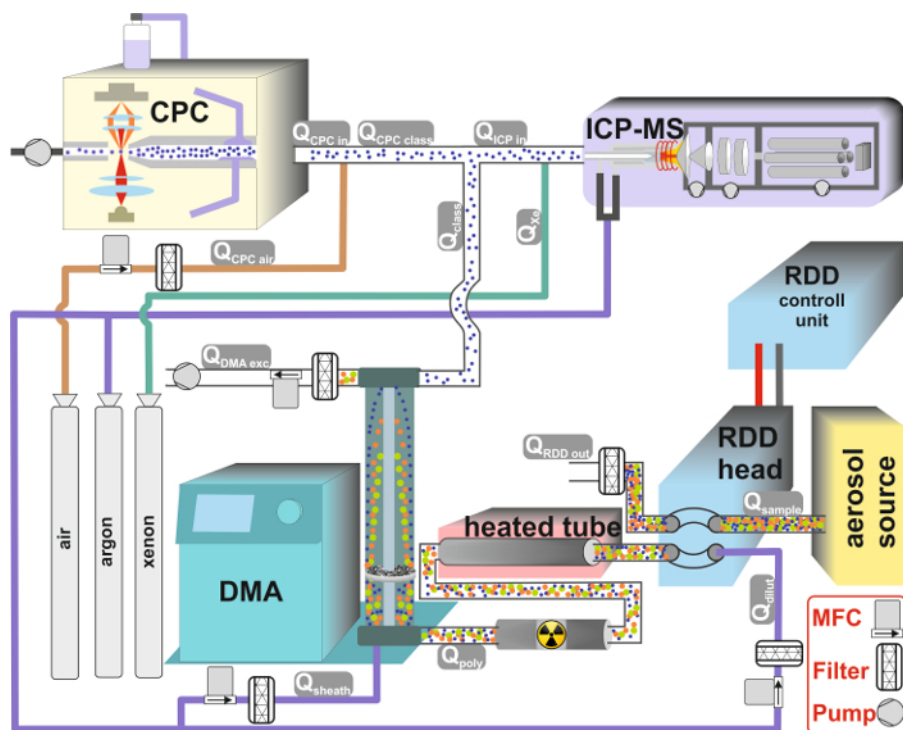

**Figure 1: Coupling Strategy for the Different Instrumental Parts in RDD-SMPS-ICPMS Setup.** Nomenclature:  $Q_{\text{sample}}$ : flow from the aerosol generator;  $Q_{\text{dilut}}$ : RDD dilution argon flow,  $Q_{\text{RDD out}}$ : raw aerosol flow out of the RDD;  $Q_{\text{poly}}$ : flow of diluted polydisperse aerosol at the DMA inlet;  $Q_{\text{sheath}}$ : DMA sheath gas flow;  $Q_{\text{class}}$ : flow of classified aerosol at the DMA outlet;  $Q_{\text{DMA exc}}$ : DMA gas excess flow;  $Q_{\text{CPC class}}$ : fraction of  $Q_{\text{class}}$  guided into the CPC;  $Q_{\text{CPC air}}$ : additional air flow for the CPC;  $Q_{\text{CPC in}}$ : total flow entering the CPC;  $Q_{\text{ICP in}}$ : fraction of  $Q_{\text{class}}$  guided into the ICPMS;  $Q_{\text{Xe}}$ : xenon flow; MFC: mass flow controller. [Please click here to view a larger version of this figure.](#)

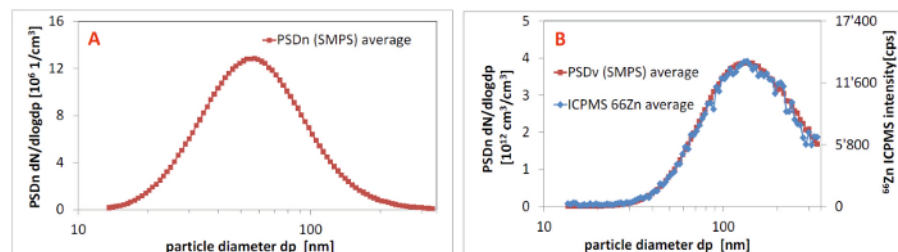

**Figure 2: SMPS-ICPMS Data of the ZnO Suspension.** (A) Number-based PSD ( $PSD_n$ ), recorded by SMPS. (B) The corresponding volume-based PSD ( $PSD_v$ ) and corrected  $^{66}\text{Zn}$  signal, detected by ICPMS. The three signals are an average over 4 SMPS scans. [Please click here to view a larger version of this figure.](#)

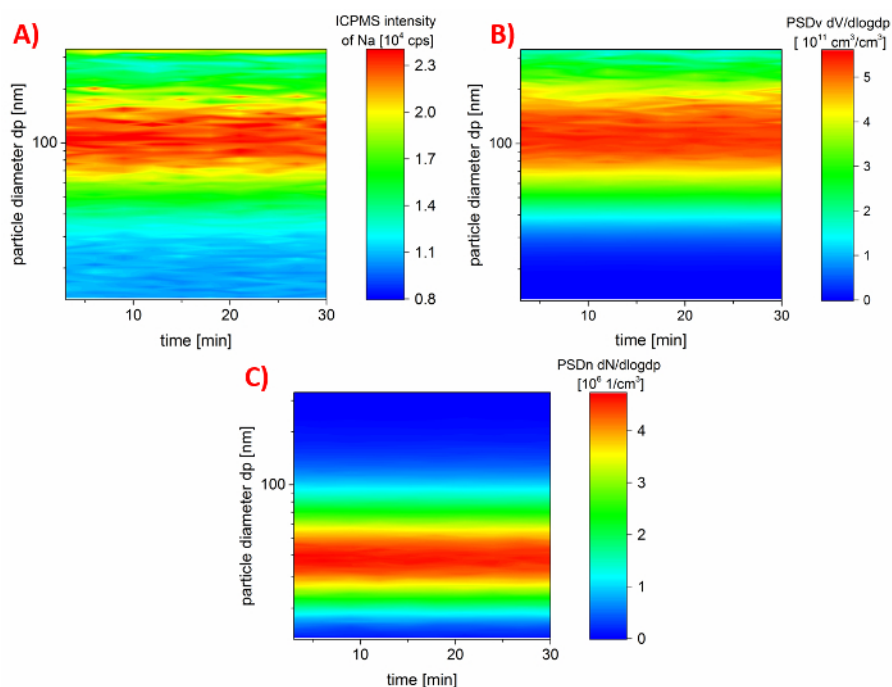

**Figure 3: SMPS-ICPMS Data of the Measurement of the NaCl Solution.** (A) ICP corrected signal of  $^{23}\text{Na}$ . (B)  $\text{PSD}_v$ . (C) Corresponding  $\text{PSD}_n$ . The SMPS concentrations and ICPMS intensities are plotted as functions of diameter and time. [Please click here to view a larger version of this figure.](#)

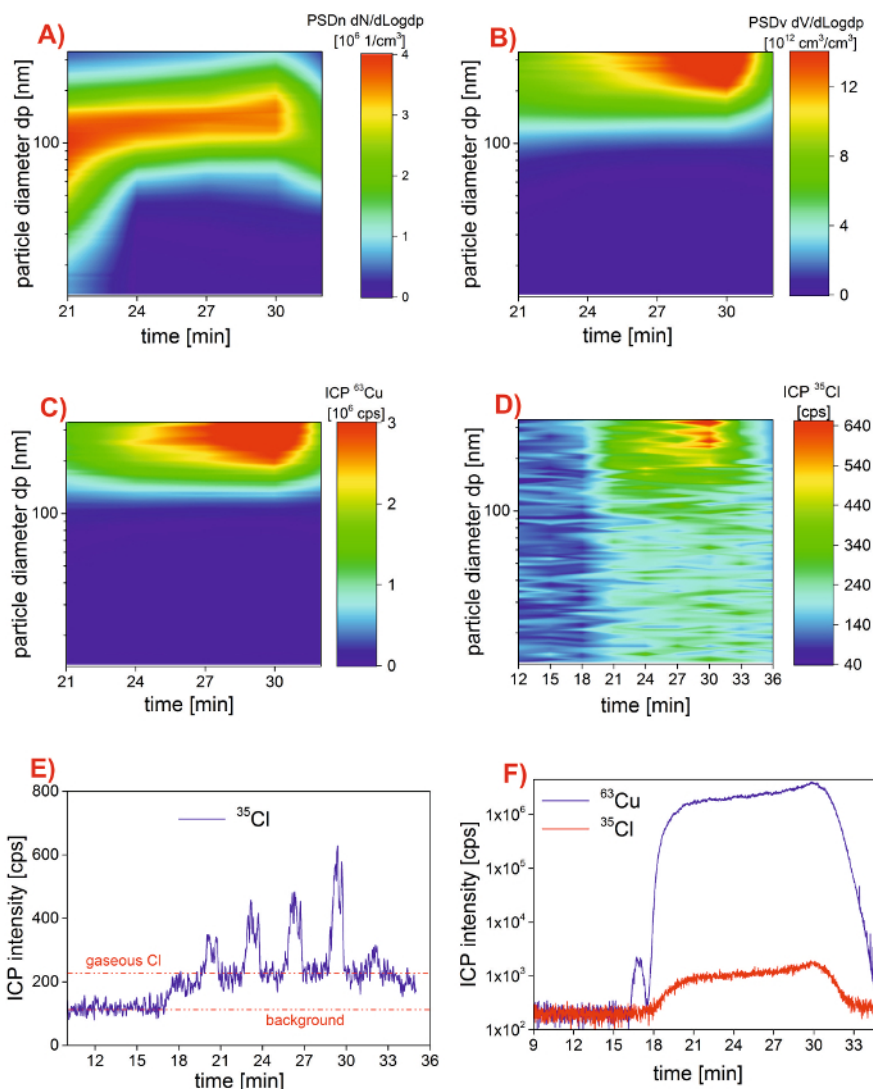

**Figure 4: SMPS-ICPMS Data from Measuring  $\text{CuCl}_2$  Evaporation by Using the TGA.** (A) 2D plot of  $\text{PSD}_n$ , (B) 2D plot of  $\text{PSD}_v$ , (C) 2D plot of  $^{63}\text{Cu}$  ICPMS signal, (D) 2D plot of  $^{35}\text{Cl}$  ICPMS signal, (E) Non-corrected raw  $^{35}\text{Cl}$  ICPMS signal vs. time, (F) ICPMS signal of  $^{63}\text{Cu}$  and  $^{35}\text{Cl}$  recorded during thermal treatment of  $\text{CuCl}_2$  by using TG-RDD-ICPMS setup (without SMPS). In both experiments (with and without SMPS) blank signals at  $25^\circ\text{C}$  are measured for about 18 min (6 SMPS scans), before starting and maintaining the heating period (for 15 min) at  $450^\circ\text{C}$ . The recording of SMPS-ICPMS signals was started at the same time as that of the TGA signals and was stopped 1 scan after switching it off (resulting in a total of 12 SMPS scans). [Please click here to view a larger version of this figure.](#)

Parameter	Value	To be tuned
Power	1350 W	yes
ICP dilution gas (argon)	0.58 L/min	Yes
Sampling depth	8 mm	Yes
Collision gas	2 mL/min	Yes (for the same set of measurements don't change this value after tuning it)
Integration time	0.2 s per isotope	Yes, if the ICP time resolution should be changed
Xe flow	4 mL/min	No (to keep the same ICP sensitivity)

**Table 1: Typical Setting of the Main ICPMS Parameters used for the RDD-SMPS-ICPMS Measurement of Aerosol Particles.**

## Discussion

Compared with the state-of-the-art existing analytical methods for aerosols, such as particle sizers, the RDD-SMPS-ICPMS combination is not only able to simultaneously acquire chemical and size information, but the time-resolved ICPMS signal also allows the determination of

each element's contribution in the overall PSD. However, only particles with a diameter below 500 nm can be measured by the current argon-operated SMPS-ICPMS. Furthermore, for a complete characterization of aerosol particles, other offline techniques are needed to determine other properties, including the morphology and the molecular structure.

The NaCl measurement is a simple example showing that a steady-state process can be controlled/monitored well with the coupled SMPS-ICPMS system. This setup can also be used in such experiments as an online analytical tool to reveal the effects of different experimental parameters on the properties of the generated particles. Any change in the particle size, and in the particle or elemental concentration, such as in the case of the thermal treatment of  $\text{CuCl}_2$  sample, can be tracked online by SMPS-ICPMS.

On the other hand, the SMPS-ICPMS combination allows not only to measure, but also to distinguish between gas and particle species. Indeed, the part of the signal related to the particulate matter can be easily distinguished from that of gaseous compounds, because the ICPMS signal of the latter covers the entire size range and does not follow a distribution shape such as that of the signal related to particles. This is due to the fact that the SMPS scanning has no effect on gaseous species, and the ICPMS measures the total intensity of a given isotope. This behavior is demonstrated by measuring Cl, which evaporates not only as particles, but also as gaseous species (**Figure 4D-4E**). Indeed, thermodynamic calculations show that under oxidizing conditions  $\text{CuCl}_2$  is evaporated at about 450 °C as  $\text{Cl}_2$  gas and as condensable species  $\text{CuCl}_2$ ,  $\text{Cu}_3\text{Cl}_3$  and  $\text{Cu}_4\text{Cl}_4$  (data not shown).

Furthermore, using the ICPMS without SMPS offers the possibility to measure the overall ICPMS signal originating either from gaseous or particulate species. Using this arrangement for the measurement of  $\text{CuCl}_2$  evaporation (**Figure 4F**), for example, shows that the stoichiometry between the evaporated Cu and Cl does not change during the heating period, because of the similar signal shape. In addition, the gaseous species can be exclusively measured by the same setup by mounting a particle filter at the RDD outlet.

In the measurement protocol there are two critical points. On the one hand, the lower ICPMS intensity curve, compared to  $\text{PSD}_v$  at large particle diameter range (e.g. in **Figure 2B**), can be explained by the fact that the consideration of multiple particle charges is not yet implemented in the data evaluation procedure (ongoing work). While the single-charge correction gives a good correlation between SMPS and ICPMS data when measuring small particles (up to 200 nm), correction for multiple charges on large particles should be established and implemented to improve the quality of the resulting information for particles above 200 nm. Another explanation of this effect could be that the larger particles are not completely decomposed and ionized in the plasma.

The second critical point is the choice of the appropriate RDD dilution factor. Indeed, like the analysis of liquid samples, the ICPMS intensity level of the different isotopes depends on the corresponding sensitivity. The Cu signal for example is about three orders of magnitude higher than that of Cl. Therefore, an appropriate value of the aerosol dilution must be set considering the ICPMS sensitivity of the measured elements. This presents a limitation of multi-element analysis for aerosols. However, the aerosol dilution value can be changed during the same experiment if the process of aerosol generation is known. For example, the dilution factor can be lowered during the period when a low particle amount is generated. Nevertheless, feeding highly particle-loaded aerosols into the DMA should be avoided to protect the CPC and the ICPMS instrumentation. In summary, depending on the sampled aerosol, a compromise between RDD dilution, matrix loading, and ICPMS sensitivity to the isotopes of interest should be found. Moreover, the time resolution of the SMPS-ICPMS setup is limited by the SMPS scan duration, which is in the range of a few minutes. However, for a fixed or narrow range of particles size, the time resolution can be enhanced.

Developing quantification methods for the overall setup is still needed (ongoing work). For thermal processes, a TGA can be used as a tool for quantification<sup>25</sup>. The quantification of liquids or suspensions can be made using appropriate standard solutions. Furthermore, designing a recirculation concept for argon, operating the DMA with air and exchanging this to argon – e.g. by means of a gas exchange device<sup>26</sup> – would allow the use of higher DMA voltage and hence an increase in the measured particle range. Finally automating the setting of the different parameters and merging the needs of SMPS and ICPMS into a single concept regarding the operating condition will reduce substantially the steps of the measurement protocol. These steps help to make the SMPS-ICPMS a powerful online setup for quantitative or qualitative analyses of different kinds of aerosols generated from liquid, suspension, or emission sources.

## Disclosures

The authors declare no competing financial interests.

## Acknowledgements

Financial support was provided by the Competence Center for Materials Science and Technology (CCMX, Project NanoAir), the Swiss National Science Foundation (Project 139136), the Swiss Nanoscience Institute (Argovia, Project NanoFil), and the Swiss Competence Center for Bioenergy Research (SCCER BIOSWEET). The authors thank Albert Schuler for his support in operating the TGA, and Adelaide Calbry-Muzyka for reviewing this manuscript.

## References

1. Chen, B.T., Crow, D.J., Use of an aerodynamic particle sizer as a real-time monitor in generation of ideal solid aerosols. *J Aerosol Sci.* 17 (6), 963-972 (1986).
2. Intra, P., Tippayawong, N., An overview of differential mobility analyzers for size classification of nanometer-sized aerosol particles. *Songklanakarini J. Sci. Technol.* 30 (2), 243-256, (2008).
3. Itoh, M., Takahashi, K., Measurement of aerosol particles by dynamic light scattering-I, effects of non-Gaussian concentration fluctuation in real time photon correlation spectroscopy. *J Aerosol Sci.* 22 (7), 815-822 (1991).
4. Nickel, C., et al., Dynamic light-scattering measurement comparability of nanomaterial suspensions. *J Nanopart Res.* 16 (2), 2260 (2014).



5. Hagendorfer, H., et al., Size-fractionated characterization and quantification of nanoparticle release rates from a consumer spray product containing engineered nanoparticles. *J Nanopart Res.* 12 (7), 2481-2494. (2010).
6. Flagan, R.C., Differential mobility analysis of aerosols: A tutorial, *KONA Powder Part J.* 26, 254-268. (2008).
7. Salgueiro-González, N., López de Alda, M.J., Muniategui-Lorenzo, S., Prada-Rodríguez, D., Barceló, D., Analysis and occurrence of endocrine-disrupting chemicals in airborne particles. *Trends Anal Chem.* 66, 45-52 (2015).
8. Pröfrock, D., Prange, A., Inductively coupled plasma-mass spectrometry (ICP-MS) for quantitative analysis in environmental and life sciences: A review of challenges, solutions, and trends. *Appl Spectrosc.* 66 (8), 843-868 (2012).
9. Gerdes, K., Carter, K.E., Calibration strategy for semi-quantitative direct gas analysis using inductively coupled plasma mass spectrometry. *Spectrochim Acta B.* 66 (9-10), 712-725 (2011).
10. Wellinger, M., Wochele, J., Biollaz, S.M.A., Ludwig, C., Online elemental analysis of process gases with ICP-OES: A case study on waste wood combustion. *Waste Manage.* 32 (10), 1843-1852 (2012).
11. Edinger, P., Tarik, M., Hess, A., Testino, A., Ludwig, C., Online Detection of Selenium and Its Retention in Reducing Gasification Atmosphere. *Energy Fuels.* 30 (2), 1237-1247 (2016).
12. Bouyssiére, B., Szpunar, J., Lobinski, R., Gas chromatography with inductively coupled plasma mass spectrometric detection in speciation analysis. *Spectrochimica Acta B.* 57 (5), 805-828 (2002).
13. Pace, H.E., Rogers, N.J., Jarolimek, C., Coleman, V.A., Higgins, C.P., Ranville, J.F., Determining transport efficiency for the purpose of counting and sizing nanoparticles via single particle inductively coupled plasma mass spectrometry. *Anal. Chem.* 83 (24), 9361-9369 (2011).
14. Laborda, F., Jiménez-Lamana, J., Bolea, E., Castillo, J.R., Selective identification, characterization and determination of dissolved silver (i) and silver nanoparticles based on single particle detection by inductively coupled plasma mass spectrometry. *J. Anal. At Spectrom.* 26 (7), 1362-1371 (2011).
15. Pease, R.F.W., Significant advances in scanning electron microscopes. *Adv Imag Elect Phys.* 150, 53-86 (2008).
16. Dax, M., Advancements in scanning electron microscopes. *Semiconductor International.* 20 (2), 60-68, (1997).
17. Kawamoto, N., et al., Transmission electron microscope as an ultimate tool for nanomaterial property studies. *Microscopy.* 62 (1), 157-175 (2013).
18. Weber, A.P., Baltensperger, U., Gäggeler, H.W., Tobler, L., Keil, R., Schmidt-Ott, A., Simultaneous in-situ measurements of mass, surface and mobility diameter of silver agglomerates *J Aerosol Sci.* 22 (SUPPL. 1), S257-S260 (1991).
19. Hess, A., Tarik, M., Ludwig, C. A hyphenated SMPS-ICPMS coupling setup: Size-resolved element specific analysis of airborne nanoparticles. *J Aerosol Sci.* 88, 109-118 (2015).
20. Hess, A., Tarik, M., Losert, S., Ilari, G., Ludwig, C., Measuring air borne nanoparticles for characterizing hyphenated RDD-SMPS-ICPMS instrumentation. *J Aerosol Sci.* 92, 130-141 (2016).
21. Hess, A., Tarik, M., Foppiano, D., Edinger, P., Ludwig, C. Online Size and Element Analysis of Aerosol Particles Released from Thermal Treatment of Wood Samples Impregnated with Different Salts. *Energy Fuels.* 30, 4072-4084 (2016).
22. Hueglin, Ch., Scherrer, L., Burtscher, H., An accurate, continuously adjustable dilution system (1:10 to 1:10<sup>4</sup>) for submicron aerosols. *J Aerosol Sci.* 28 (6), 1049-1055. (1997).
23. Kulkarni, P., Baron, P.A., Willeke, K., *Aerosol Measurement: Principles, Techniques, and Applications.* 3rd Edition, 18-19 (2011).
24. Wiedensohler, A., An approximation of the bipolar charge distribution for particles in the submicron size range. *J Aerosol Sci.* 19 (3), 387-389 (1988).
25. Ludwig, C., Wochele, J., Jörmann, U., Measuring evaporation rates of metal compounds from solid samples. *Anal Chem.* 79 (7), 2992-2996 (2007).
26. Kovacs, R., Nishiguchi, K., Utani, K., Günther, D., Development of direct atmospheric sampling for laser ablation-inductively coupled plasma-mass spectrometry. *J. Anal. At Spectrom.* 25 (2), 142-147. (2010).